

Key to wiring diagrams 19 to 32 inclusive

No	Description	No	Description
1	Battery	49	Fuel sender unit
2	Lighting	50	Fuel pump
3	Dip switch	51	Relay module
4	Dipped beam headlight	52	Automatic transmission starter inhibitor switch
5	Main beam headlight	53	Accelerator pedal switch
6	RH sidelight	54	Diagnostic connector
7	LH sidelight	55	Stepper motor
8	Number plate illumination light	56	Manifold PTC heater
9	RH tail light	57	Oil pressure switch
10	Brake light switch	58	Brake fluid level switch
11	LH tail light	59	Ignition/charging warning light
12	Horn	60	Oil pressure warning light
13	Horn switch	61	Brake system warning light
14	Direction indicator switch	62	Tachometer
15	RH front direction indicator light	63	Coolant temperature gauge
16	LH front direction indicator light	64	Fuel gauge
17	Heater switch	65	Main beam warning light
18	Heater motor	66	LH indicator warning light
19	Windscreen wiper motor	67	RH indicator warning light
20	Ignition switch	68	Instrument pack
21	Headlight flasher switch	69	Intake air temperature sensor
22	Rear foglight switch	70	Interior light
23	Direction indicator/hazard warning light unit	71	Radio/cassette player
24	Automatic transmission selector indicator light	72	RH speaker
25	Windscreen washer pump	73	LH speaker
26	Heated rear window switch	74	Auxiliary cooling fan relay
27	Heated rear window element	75	LH brake light
28	Hazard warning light	76	RH brake light
29	Hazard warning light switch	77	Dim-dip relay
30	Auxiliary cooling fan	78	Instrument panel illumination
31	Purge valve	79	Distributor
32	Fusible links	80	RH rear direction indicator light
33	LH side repeater light	81	LH rear direction indicator light
34	RH side repeater light	82	Voltage stabiliser
35	Driver's door interior light switch	83	Engine management ECU
36	Passenger door interior light switch	84	Lambda sensor
37	Dim-dip resistor	85	Reversing light switch
38	Auxiliary cooling fan switch	86	Rear foglight
39	Alternator	87	Fuel injector
40	Starter relay	88	Wiper column switch
41	Ignition coil	89	Starter
42	Crankshaft sensor	90	Lambda sensor relay
43	Throttle potentiometer	91	Reversing lights
44	Coolant temperature sensor	92	Direction indicator relay
45	Fuel pump relay	93	Fuse
46	Main relay	94	Line fuse
47	Manifold PTC heater relay	95	Radio fuse
48	Inertia switch		

Cable colour code

BL	Blue	O	Orange
BK	Black	P	Pink
BR	Brown	PU	Purple
G	Green	R	Red
GR	Slate	W	White
LG	Light green	Y	Yellow

When a cable has two colour code letters, the first denotes the main colour and the second denotes the tracer colour

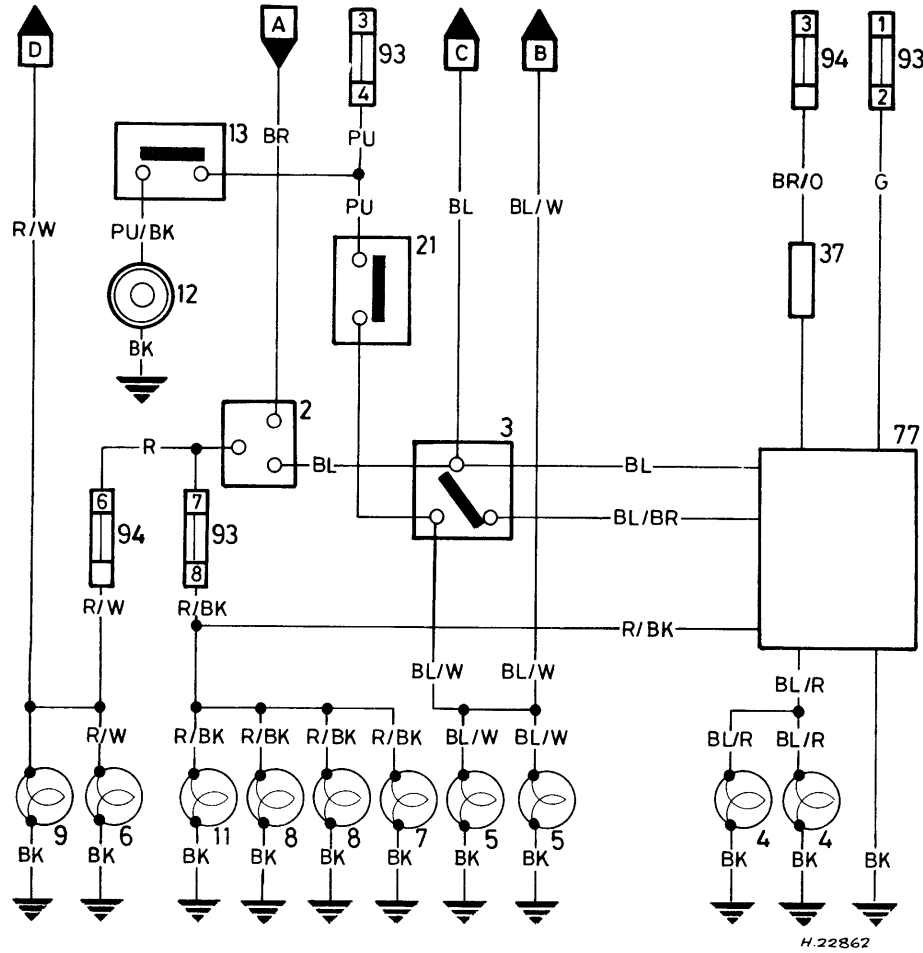

Wiring diagram 19 - Dim-dip lighting and horn circuit (fuel-injected models)

- | | |
|---------------------------------|-------------------------|
| A To power distribution circuit | C To foglight circuit |
| B To instrument circuit | D To instrument circuit |

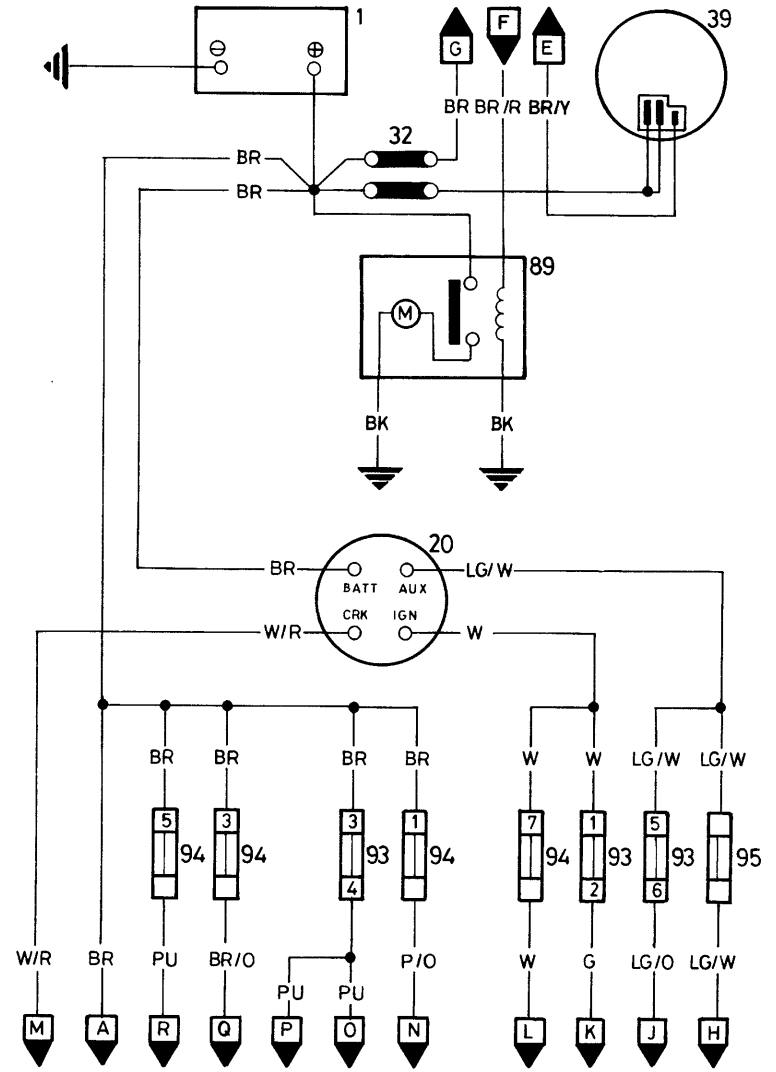

Wiring diagram 20 - Power distribution circuit (fuel-injected models)

- | | |
|-------------------------------------|-----------------------------|
| E to Wiring diagram 22 | M to Wiring diagram 21 |
| F to Wiring diagram 21 | N to Wiring diagrams 23, 28 |
| G to Wiring diagram 21 | O to Wiring diagrams 19, 26 |
| H To Wiring diagram 26 | P to Wiring diagram 27 |
| J to Wiring diagrams 22, 24, 25, 31 | Q to Wiring diagram 27 |
| K to Wiring diagrams 19, 23, 32 | R to Wiring diagram 25 |
| L to Wiring diagrams 21, 22 | A to Wiring diagram 19 |

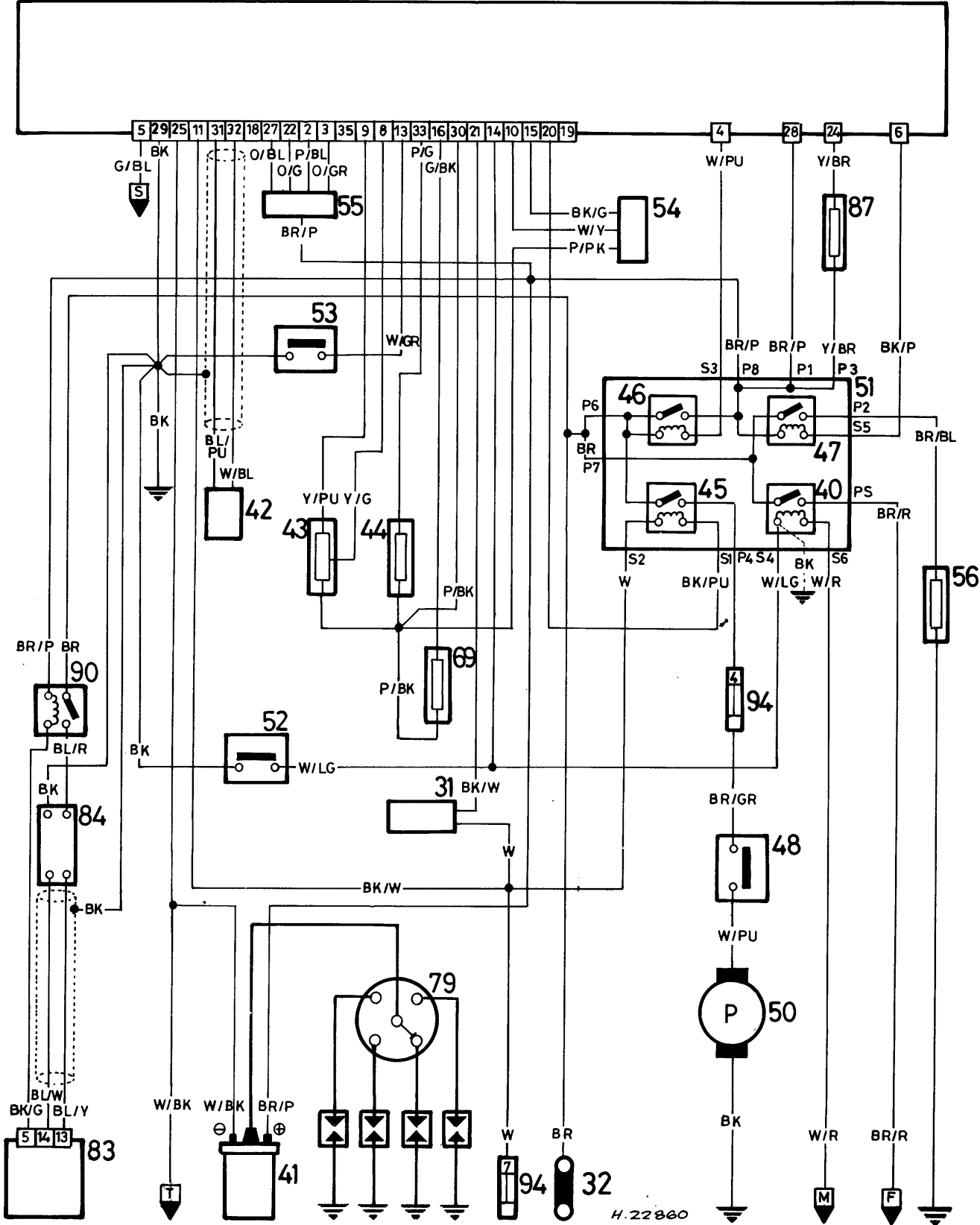

Wiring diagram 21 - Engine management circuit (fuel-injected models)

F to Wiring diagram 20
M to Wiring diagram 20
S to Wiring diagram 22
T to Wiring diagram 22

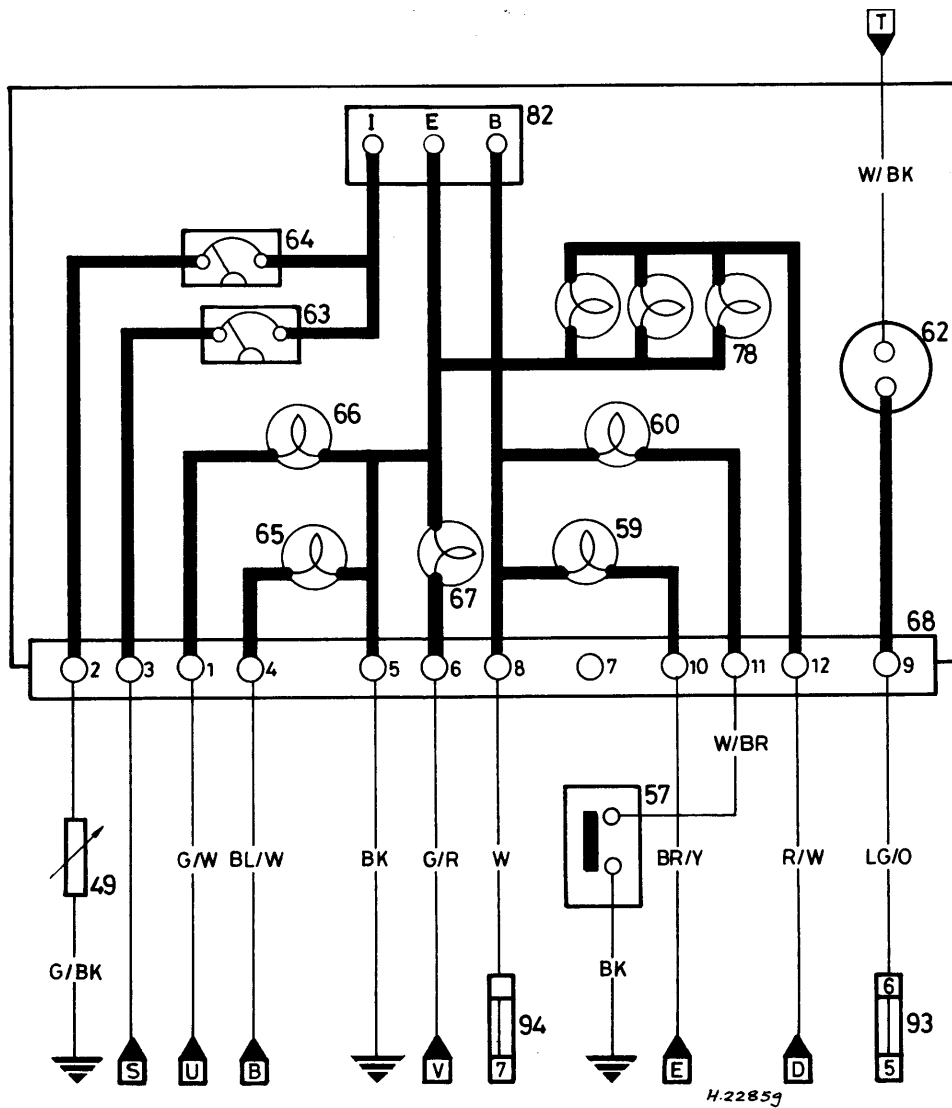

Wiring diagram 22 - Instrument circuit (fuel-injected models)

E to Wiring diagram 20
 B to Wiring diagram 19
 D to Wiring diagram 19
 S to Wiring diagram 21

T to Wiring diagram 21
 U to Wiring diagram 23
 V to Wiring diagram 23

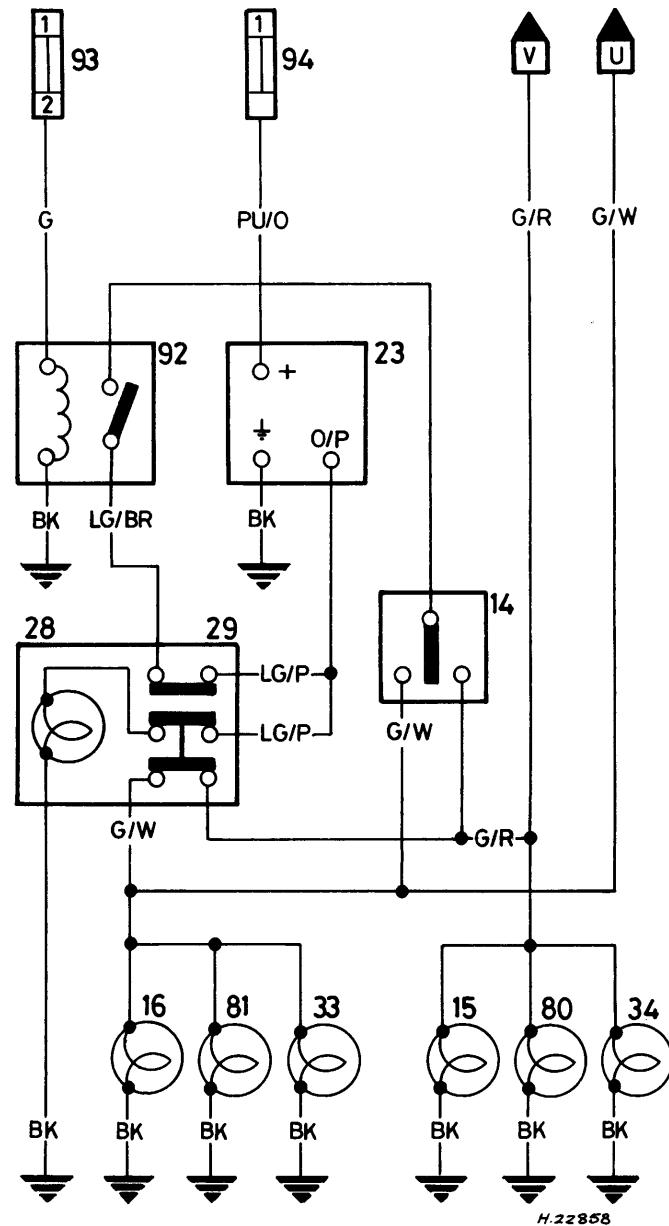

Wiring diagram 23 - Direction indicator and hazard warning light circuit (fuel-injected models)

U to Wiring diagram 22

V to Wiring diagram 22

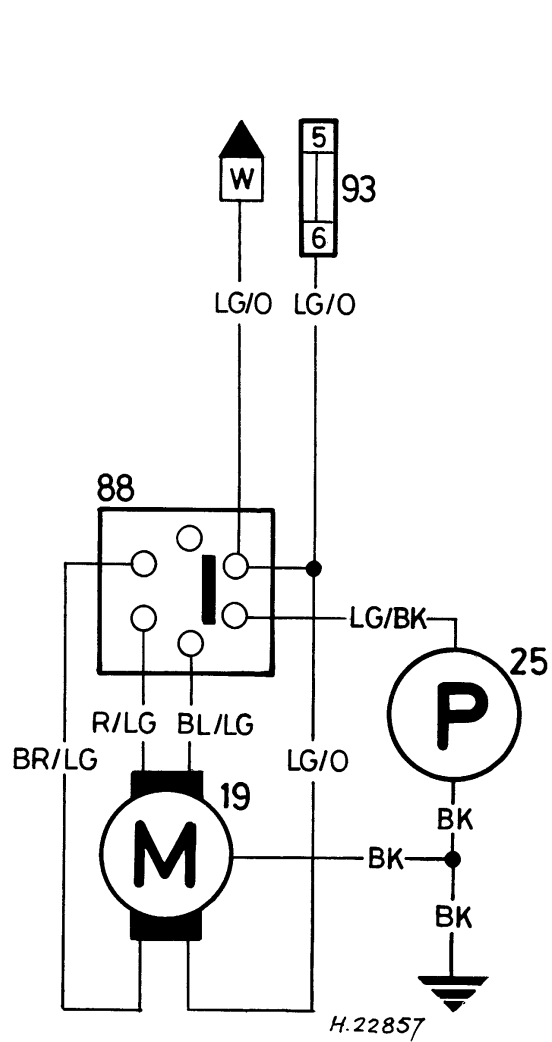

Wiring diagram 24 - Wash/wipe circuit
(fuel-injected models)

W to Wiring diagram 30

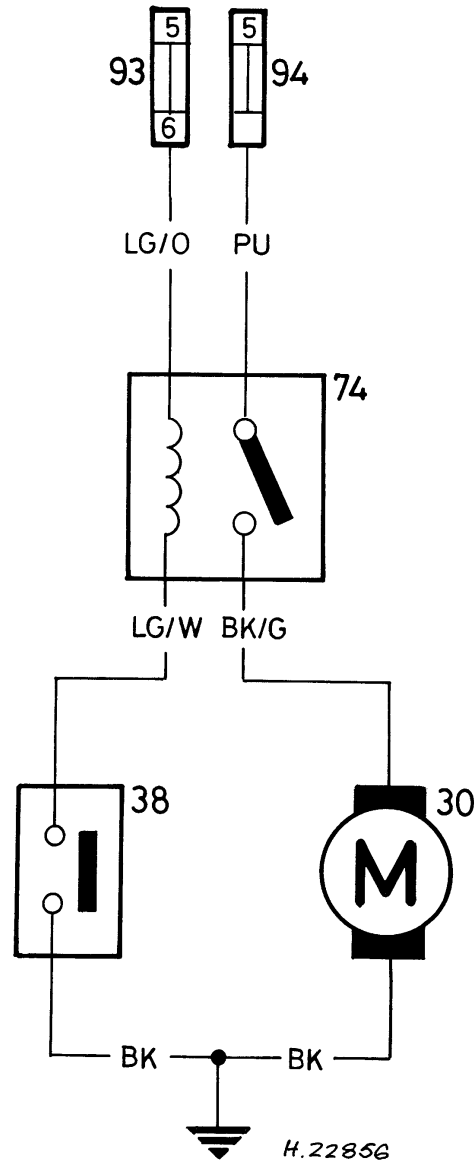

Wiring diagram 25 - Auxiliary cooling fan circuit
(fuel-injected models)

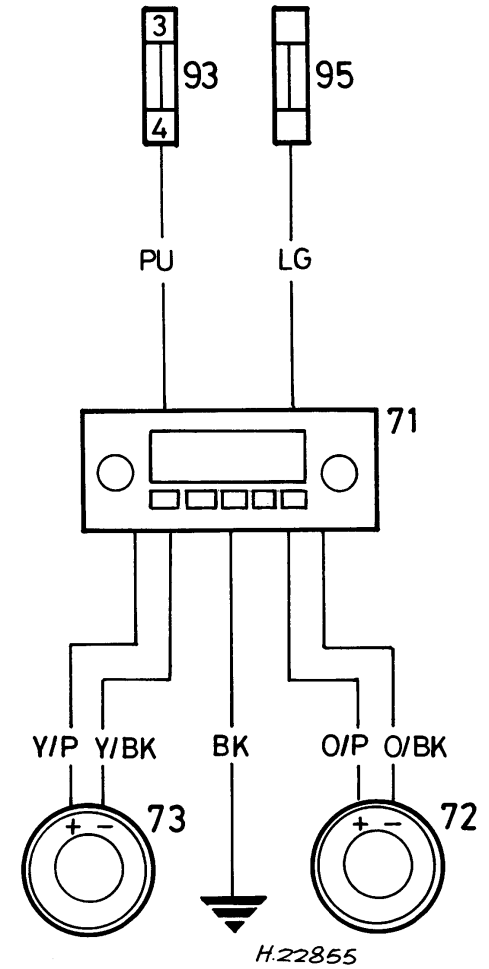

Wiring diagram 26 - Radio/cassette player circuit
(fuel-injected models)

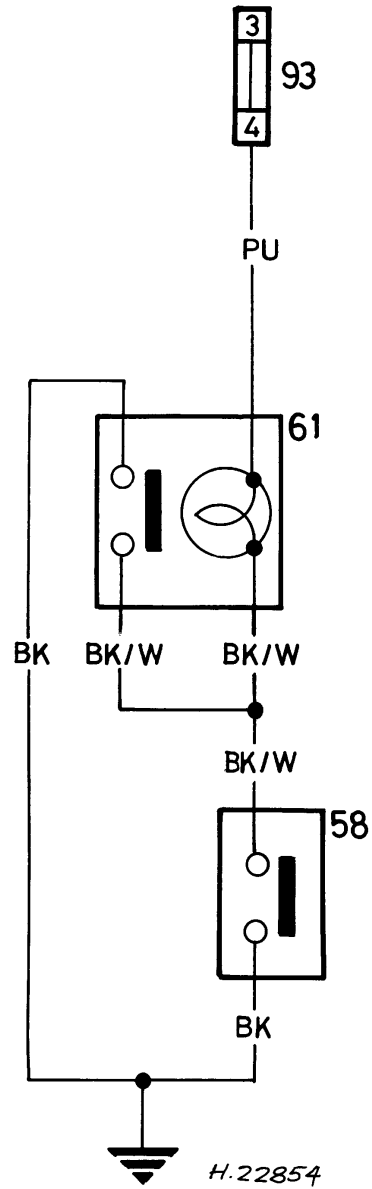

Wiring diagram 27 - Brake test circuit
(fuel-injected models)

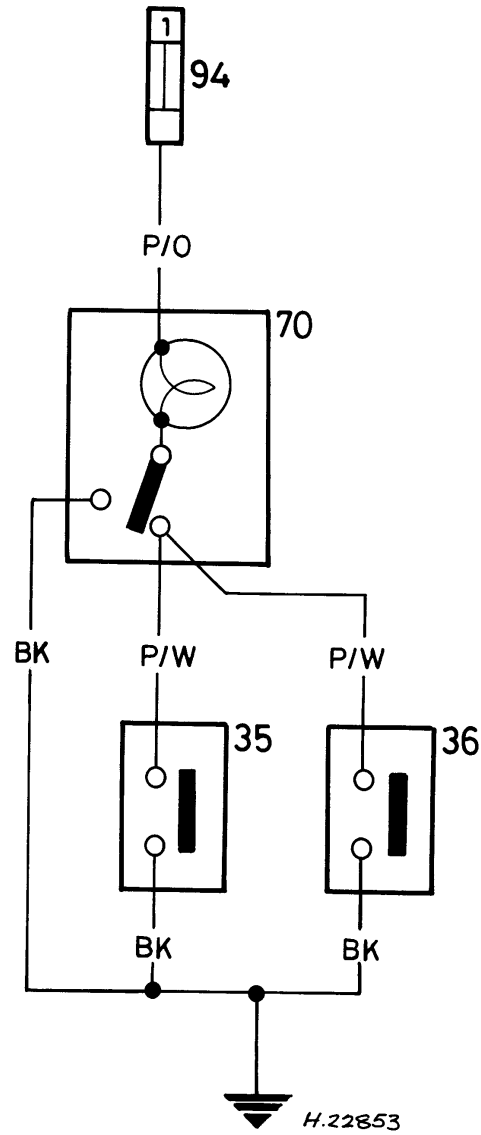

Wiring diagram 28 - Interior light circuit
(fuel-injected models)

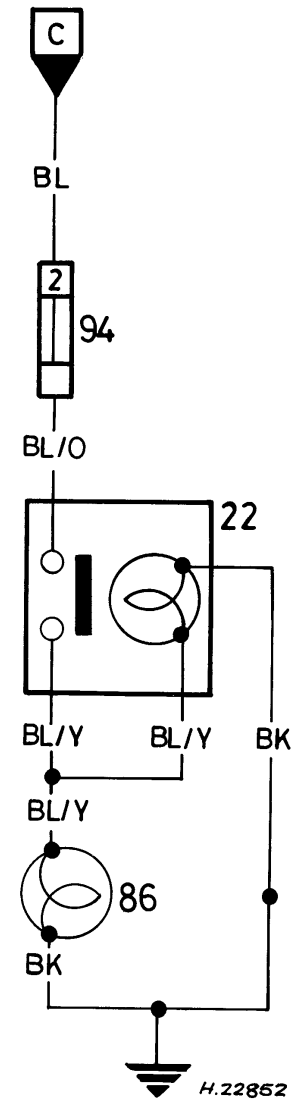

Wiring diagram 29 - Foglight circuit
(fuel-injected models)

C to Wiring diagram 19

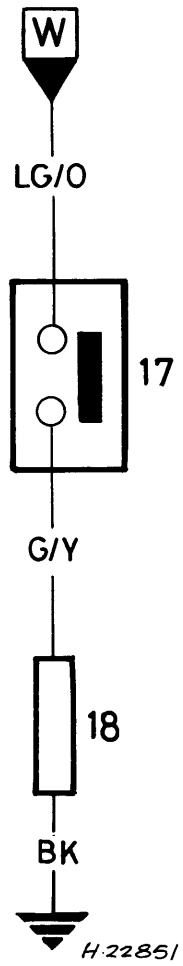

Wiring diagram 30 - Heater circuit
(fuel-injected models)

W to Wiring diagram 24

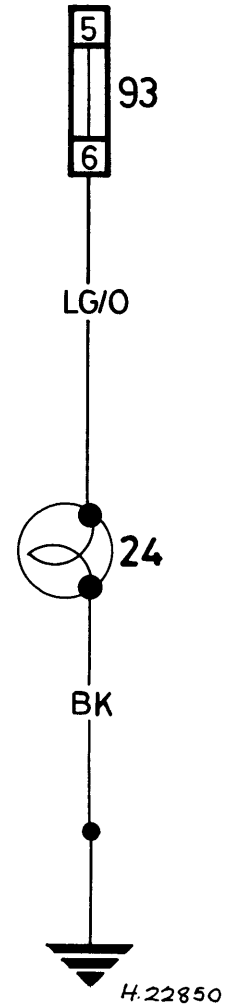

Wiring diagram 31 - Automatic transmission selector
illumination circuit (fuel-injected models)

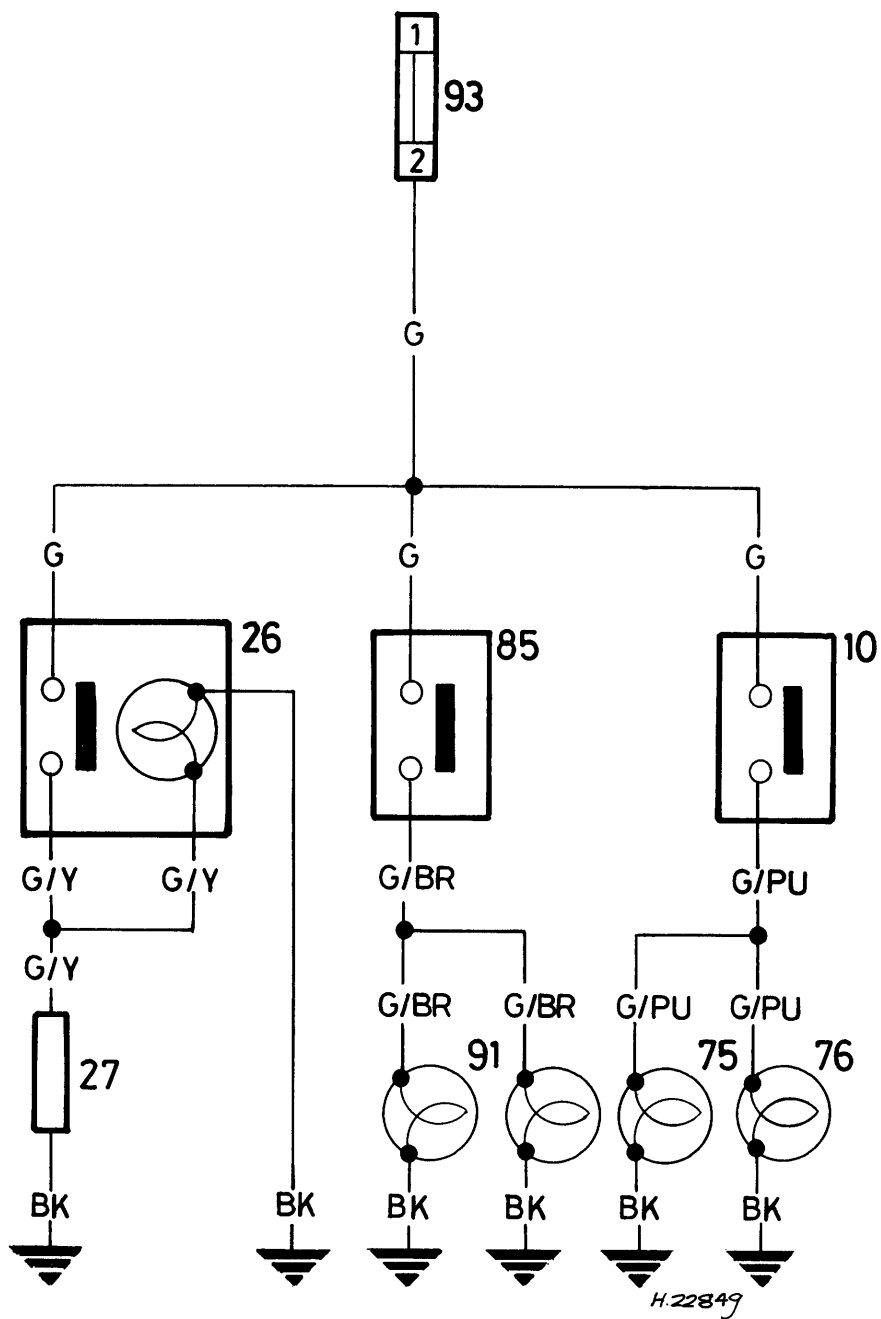

Wiring diagram 32 - Reversing light, stop-light and heated rear window circuit (fuel-injected models)